

Oxford Dendrochronology Laboratory
Report 2011/33

**THE TREE-RING DATING OF
PLAS YM MHENRHOS
PENRHOS,
PWLLELI,
GWYNEDD
(NGR SH 355 342)**



Summary

The floor timbers from this building produced a 195-year site chronology dated to the period 1413–1607, with one floor beam being derived from a tree felled in spring 1592, a second beam being from a tree felled after 1600, and a joist being from a tree felled in summer 1608. The floor was most likely constructed in **1608**, or within a year or so after this date, using at least one stockpiled or re-used timber. Three principal rafters sampled from the roof appear to have been derived from a single parent tree. The 73-year ring-width series from this tree could not be dated, but the roof was thought to be later than the floor.

Authors: Dr D. Miles FSA and Dr M. C. Bridge FSA
Oxford Dendrochronology Laboratory
Mill Farm
Mapledurham
Oxfordshire
RG4 7TX

October 2011



A report commissioned by The North West Wales Dendrochronology Project in partnership with The Royal Commission on the Ancient and Historical Monuments in Wales (RCAHMW).

The Tree-Ring Dating of Plas ym Mhenrhos, Penrhos, Gwynedd (NGR SH 355 342)

BACKGROUND TO DENDROCHRONOLOGY

The basis of dendrochronological dating is that trees of the same species, growing at the same time, in similar habitats, produce similar ring-width patterns. These patterns of varying ring-widths are unique to the period of growth. Each tree naturally has its own pattern superimposed on the basic ‘signal’, resulting from genetic variations in the response to external stimuli, the changing competitive regime between trees, damage, disease, management etc.

In much of Britain the major influence on the growth of a species like oak is, however, the weather conditions experienced from season to season. By taking several contemporaneous samples from a building or other timber structure, it is often possible to cross-match the ring-width patterns, and by averaging the values for the sequences, maximise the common signal between trees. The resulting ‘site chronology’ may then be compared with existing ‘master’ or ‘reference’ chronologies.

This process can be done by a trained dendrochronologist using plots of the ring-widths and comparing them visually, which also serves as a check on measuring procedures. It is essentially a statistical process, and therefore requires sufficiently long sequences for one to be confident in the results. There is no defined minimum length of a tree-ring series that can be confidently cross-matched, but as a working hypothesis most dendrochronologists use series longer than at least fifty years.

The dendrochronologist also uses objective statistical comparison techniques, these having the same constraints. The statistical comparison is based on programs by Baillie & Pilcher (1973, 1984) and uses the Student’s *t*-test. The *t*-test compares the actual difference between two means in relation to the variation in the data, and is an established statistical technique for looking at the significance of matching between two datasets that has been adopted by dendrochronologists. The values of ‘*t*’ which give an acceptable match have been the subject of some debate; originally values above 3.5 being regarded as acceptable (given at least 100 years of overlapping rings) but now 4.0 is often taken as the base value. It is possible for a random set of numbers to give an apparently acceptable statistical match against a single reference curve – although the visual analysis of plots of the two series usually shows the trained eye the reality of this match. When a series of ring-widths gives strong statistical matches in the same position against a number of independent chronologies the series becomes dated with an extremely high level of confidence.

One can develop long reference chronologies by cross-matching the innermost rings of modern timbers with the outermost rings of older timbers successively back in time, adding data from numerous sites. Data now exist covering many thousands of years and it is, in theory, possible to match a sequence of unknown date to this reference material.

It follows from what has been stated above that the chances of matching a single sequence are not as great as for matching a tree-ring series derived from many individuals, since the process of aggregating individual series will remove variation unique to an individual tree, and reinforce the common signal

resulting from widespread influences such as the weather. However, a single sequence can be successfully dated, particularly if it has a long ring sequence.

Growth characteristics vary over space and time, trees in south-eastern England generally growing comparatively quickly and with less year-to-year variation than in many other regions (Bridge, 1988). This means that even comparatively large timbers in this region often exhibit few annual rings and are less useful for dating by this technique.

When interpreting the information derived from the dating exercise it is important to take into account such factors as the presence or absence of sapwood on the sample(s), which indicates the outer margins of the tree. Where no sapwood is present it may not be possible to determine how much wood has been removed, and one can therefore only give a date after which the original tree must have been felled. Where the bark is still present on the timber, the year, and even the time of year of felling can be determined. In the case of incomplete sapwood, one can estimate the number of rings likely to have been on the timber by relating it to populations of living and historical timbers to give a statistically valid range of years within which the tree was felled. For this region the estimate used is that 95% of oaks will have a sapwood ring number in the range 11 – 41 (Miles 1997).

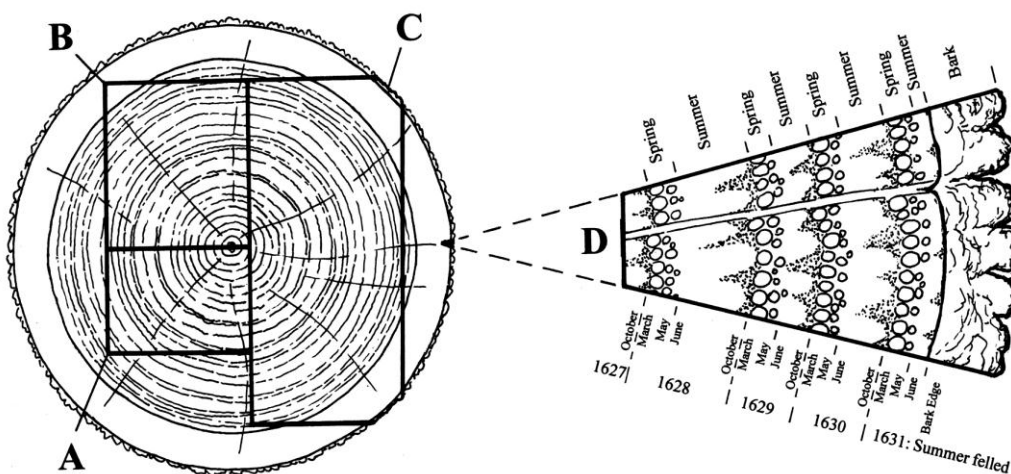

Section of tree with conversion methods showing three types of sapwood retention resulting in **A** *terminus post quem*, **B** a felling date range, and **C** a precise felling date. Enlarged area **D** shows the outermost rings of the sapwood with growing seasons (Miles 1997, 42)

PLAS YM MHENRHOS

Plas-ym-Mhenros is a substantial Snowdonian house of C17th origin with C18th/C19th additions, including the agricultural ranges adjacent to the house. The core of the range is a house of Snowdonian plan-type with massive end chimney, moderately chamfered beams, including the partition beam for the twin outer rooms. A fireplace stair formerly led to the two first floor chambers, the inner chamber having a fireplace. C18th/C19th alterations (in more than one phase) included the addition of a parlour wing and service-rooms at the rear. The roof-trusses are of C18th type with lapped collars and the

dormers have been renewed in the C19th. Plas-ym-Mhenrhos is noted in the Caernarvonshire Inventory, Vol. III: West (1964), Mon. 1693, p. 89b.

A wooden panel is preserved in the house with the inscription IHS / 1678. The date inscription does not date the house; the Caernarvonshire Inventory suggests that it is the former cover of the font at Penrhos parish church, also dated 1678.

The farm buildings (principally stable and barn) are of C19th date contemporary with the modernisation of the house. They appear to have included accommodation for servants in the part of the range nearest the house which retains the round-headed windows also present in the Victorian dormers of the house. R.F. Suggett/RCAHMW/October 2011. Extract from Coflein (RCAHMW's on-line database), NPRN 16761.

SAMPLING

Sampling took place in July 2011. All the samples were of oak (*Quercus* spp.). Core samples were extracted using a 15mm diameter borer attached to an electric drill. They were numbered using the prefix **pym**. The samples were removed for further preparation and analysis. Cores were mounted on wooden laths and then these were polished using progressively finer grits down to 400. The samples were measured under a binocular microscope on a purpose-built moving stage with a linear transducer, attached to a desktop computer allowing the measurement of ring-widths to the nearest 0.01 mm using DENDRO for WINDOWS, written by Ian Tyers (Tyers 2004), which was also used for subsequent analysis, along with other programs written in BASIC by D Haddon-Reece, and re-written in Microsoft Visual Basic by M R Allwright and P A Parker.

RESULTS AND DISCUSSION

Basic information about the samples and their origins are shown in Table 1 and illustrated in Fig 1. The two series from 9th joist matched each other and were combined into a single series (**pym06**) for subsequent analysis. The seven series from the floor timbers all matched each other (Table 2a) and a 195-year site chronology, **PLASMNRS**, was derived from them. This series dates to the years 1413–1607, the best evidence being shown in Table 3. The relative positions of overlap of the timbers are shown in Fig 2, which also shows that the timbers retaining complete sapwood were felled over a long period. The north floor beam was from a tree felled in spring 1592, whilst the south floor beam was from a tree felled after 1600, and one joist was from a tree felled in summer 1608. This makes the most likely date of the construction of the floor in 1608, or within a year or two afterwards, but using at least some stockpiled timber. This seems to be a feature of buildings in the Pwllheli area, being noted also in Mathan House, and Clogwyn Bach, which unfortunately remain undated.

The roof was thought to be later (Richard Suggett, pers comm.). The three principal rafters sampled appear to have come from the same tree (Table 2b). The tree ring width series were therefore meant to form a second site chronology (**pym8910**). This 73-year long sequence failed to date, though this is perhaps not surprising for a single tree, relatively short sequence.

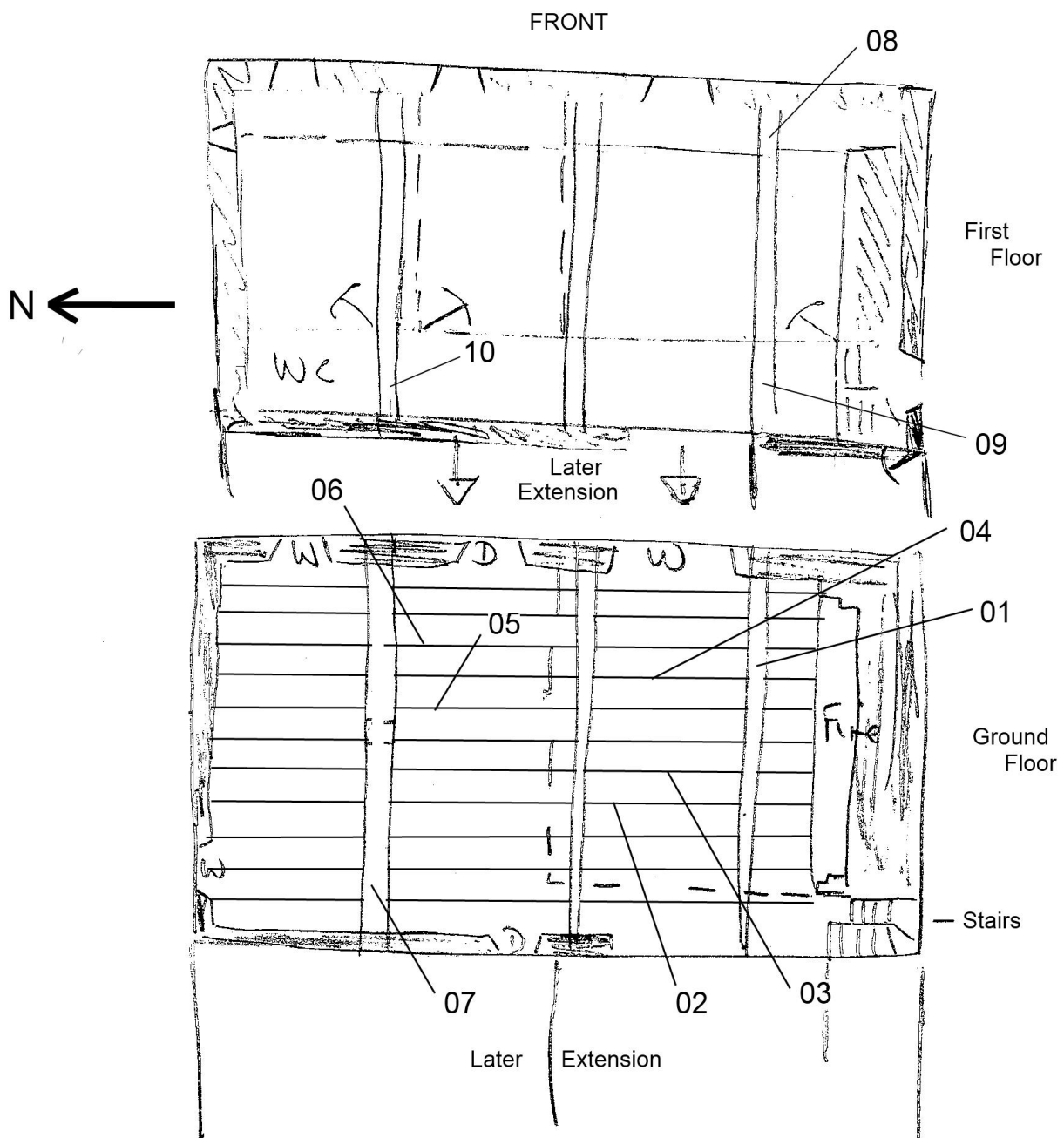

Figure 1: Sketch plan of the building (M Dunn) annotated to show approximate positions of the samples taken

Table 1: Details of samples taken from Plas ym Mhenrhos.

Sample number	Timber and position	Date of series	H/S boundary date	Sapwood complement	No of rings	Mean width mm	Std devn mm	Mean sens	Felling date range
* pym01	South beam	1473-1599	1564	35	127	0.87	0.65	0.24	after 1600
* pym02	Joist, 4 th from W	1415-1553	c1569	c17	139 +33NM	0.76	0.40	0.21	after c1586
* pym03	Joist, 5 th from W	1413-1507	-	-	95	1.15	0.59	0.23	after 1518
* pym04	Joist, 8 th from W	1457-1570	-	-	114	0.82	0.37	0.22	after 1581
* pym05	Joist, 7 th from W	1457-1573	1573	H/S +19NM	117	0.74	0.48	0.22	after 1593
pym06a	Joist 9 th from W	1498-1580	1581	+1 to H/S	83	0.71	0.38	0.24	-
pym06b	<i>ditto</i>	1566-1607	1582	25½C	42	0.86	0.29	0.22	-
* pym06	Mean of 06a + 06b	1498-1607	1582	25½C	110	0.75	0.35	0.23	Summer 1608
* pym07	North beam	1429-1591	1572	19¼C	163	0.95	0.56	0.25	Spring 1592
pym08	East principal rafter, S truss	-	-	25½C	62	1.51	0.72	0.38	-
pym09	West principal rafter, S truss	-	-	27½C	69	1.29	0.62	0.34	-
pym10	West principal rafter, N truss	-	-	33¼C	73	1.33	0.48	0.32	-
pym8910	Mean of 08 + 09 + 10	-	-	33¼C	73	1.39	0.55	0.32	-
* = included in Site Master PLASMNRS		1413-1607			195	0.93	0.45	0.17	

Key: H/S bdry = heartwood/sapwood boundary - last heartwood ring date; ¼C = complete sapwood, felled the following spring; ½C = complete sapwood, felled the following summer; std devn = standard deviation; mean sens = mean sensitivity; NM = not measured;

Table 2a: Cross-matching between dated samples

Sample	<i>t</i> -values					
	pym02	pym03	pym04	pym05	pym06	pym07
pym01	2.8	3.8	3.8	1.8	1.0	4.5
pym02		7.4	3.2	3.5	2.9	3.2
pym03			10.7	4.9	-	3.8
pym04				6.9	3.0	4.7
pym05					1.8	4.1
pym06						5.8

- = no calculation made, overlap less than 20 years



A report commissioned by The North West Wales Dendrochronology Project in partnership with The Royal Commission on the Ancient and Historical Monuments in Wales (RCAHMW).

Table 2b: Cross-matching between samples **08, 09** and **10**

<i>t</i> -values		
Sample	pym09	pym10
pym08	15.6	9.3
pym09		11.1

Table 3: Dating evidence for the site master **PLASMNRS AD 1413–1607** against dated reference chronologies, regional chronologies in **bold**

<i>County or region:</i>	<i>Chronology name:</i>	<i>Short publication reference:</i>	<i>File name:</i>	<i>Spanning:</i>	<i>Overlap (yrs):</i>	<i>t-value:</i>
Wales	Plas y Dduallt, Maentwrog	(Miles <i>et al</i> 2011)	GWYNEDD5	1355-1604	192	11.9
Wales	Clenennau, Dolbenmaen	(Miles <i>et al</i> 2006)	BDGLRT10	1406-1570	158	11.4
Wales	Pengwern Old Hall	(Miles <i>et al</i> 2003)	PENGWERN	1353-1521	109	9.1
Wales	Beddgelert	(Nayling pers comm)	BEDD_T6	1302-1529	117	8.8
Wales	Cwm Farm, Cwm Cynfal	(Miles <i>et al</i> 2012)	CWMFM1	1364-1567	155	8.7
Wales	Hafodysbyty, Ffestiniog	(Miles <i>et al</i> 2012)	HDYSBYTY	1374-1497	84	8.7
Wales	Parc Llanfrothen	(Miles <i>et al</i> 2006)	BDGLRT22	1386-1669	195	8.7
Wales	Bryn yr Odyn, Gwynedd	(Miles <i>et al</i> 2010)	BRYNRDYN	1388-1586	174	8.5
Wales	Derwyn-bach, Dolbenmaen	(Miles <i>et al</i> 2006)	BDGLRT15	1385-1548	136	8.3
Wales	Pant-glas-uchaf, Clynnog	(Miles <i>et al</i> 2006)	BDGLRT14	1413-1573	161	8.1
Wales	Plas Tan-y-Bwlch, Maentwrog	(Miles <i>et al</i> 2006)	BDGLRT23	1411-1535	123	7.8
Wales	Dylasau Ichaf, Caernarfonshire	(Miles <i>et al</i> 2011)	DYLASAU1	1412-1592	180	7.8
Wales	Ffridd-isaf, Betws Garmon	(Miles <i>et al</i> 2006)	BDGLRT1	1423-1599	177	7.4

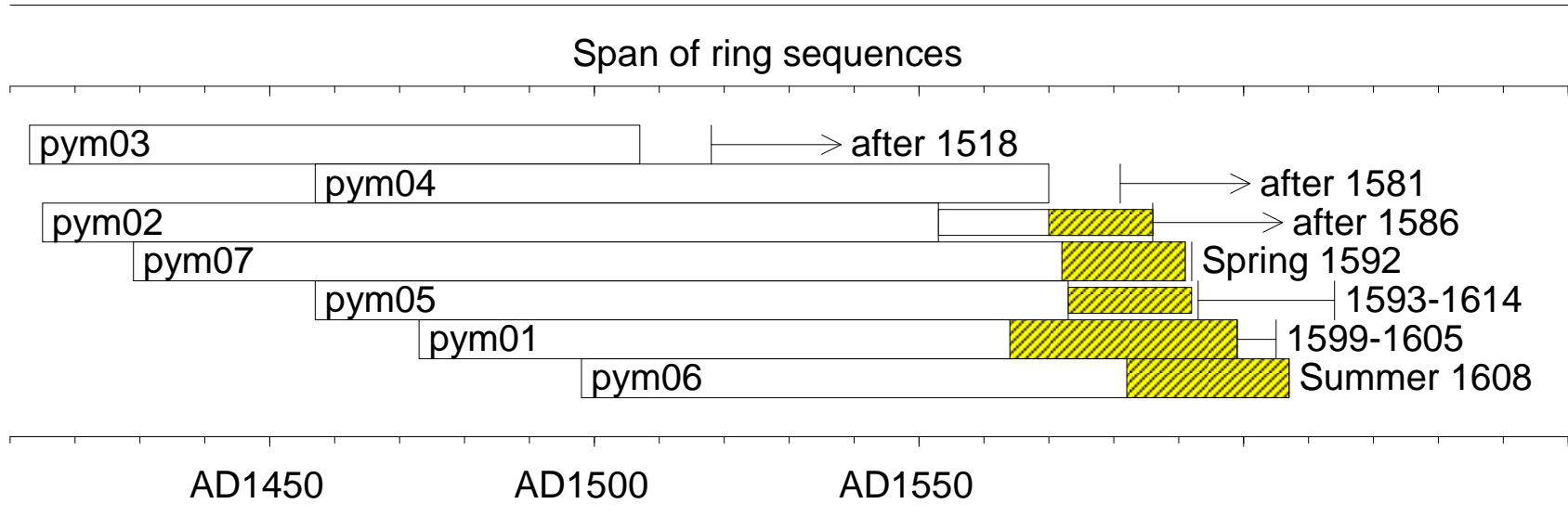

Figure 2: Bar diagram showing the relative positions of overlap of the dated series, along with their interpreted likely, or actual, felling date ranges. Hatched yellow sections represent sapwood rings, and narrow sections of bar represent additional unmeasured rings

ACKNOWLEDGEMENTS

This study was commissioned by Margaret Dunn of the North-West Wales Dendrochronology Project, in collaboration with the HLF Llyn Landscape Partnership Scheme. We are grateful to the owner, Mr A. Sturkey, for allowing access to their building, and to Richard Suggett of the Royal Commission on Ancient and Historic Monuments of Wales who assisted in the interpretation on site, and provided useful background information.

REFERENCES

- Baillie, M.G.L. and Pilcher, J.R. (1973) *A simple cross-dating program for tree-ring research*. **Tree Ring Bulletin**, 33, 7-14.
- Bridge, M. C. (1988) The dendrochronological dating of buildings in southern England, **Medieval Archaeology**, 32, 166-174.
- English Heritage (1998) *Guidelines on producing and interpreting dendrochronological dates*, **English Heritage, London**.
- Miles, D. (1997) The interpretation, presentation, and use of tree-ring dates, **Vernacular Architecture**, 28, 40-56.
- Miles, D. H., Worthington, M. J. and Bridge, M. C. (2003) Tree-ring dates, **Vernacular Architecture**, 34, 109-113.
- Miles, D. H., Worthington, M. J. and Bridge, M. C. (2006) Tree-ring dates, **Vernacular Architecture**, 37, 118-132.
- Miles, D. H., Worthington, M. J., Bridge, M. C., Suggett, R. and Dunn, M. (2010) Tree-ring dates, **Vernacular Architecture**, 41, 110-118.
- Miles, D. H., Bridge, M. C., Suggett, R. and Dunn, M. (2011) Tree-ring dates, **Vernacular Architecture**, 42, in press.
- Miles, D. H., Bridge, M. C., Suggett, R. and Dunn, M. (2012) Tree-ring dates, **Vernacular Architecture**, 43, in prep.
- Tyers, I. (2004) *Dendro for Windows Program Guide 3rd edn*, **ARCUS Report**, 500b.